

HIGH POWER CONTROLLERS

BAC 2000 | BAC 4000 | BAC 8000



The ASI BAC 2000, BAC 4000 and BAC 8000 are a series of high density motor controllers that utilize the latest in sinusoidal flux vector control to ensure smooth and quiet brushless DC motor operation and efficient vehicle operation. They can operate over a nominal battery voltage range of 36VDC to 72VDC.

A robust MOSFET-based three phase bridge provides peak efficiencies of up to 99%, with no audible noise. Hall sensor based motor commutation, and sensorless commutation are also supported.

Programmable performance mapping allows throttle and regenerative braking inputs to be adjusted via ASI's BACDoor™ PC configuration/Engineering software to meet specific performance requirements.

Numerous programmable protection features including motor/controller temperature, battery over/under voltage, and motor/battery current limits increase controller and motor longevity.

Smooth Performance. Silent. Configurable. Reliable.

- Can be attached to additional heat sinking to significantly increase performance
- PWM drive for low ripple current and silent drive
- Field oriented control for increased efficiency and smooth motor operation
- Multiple analog and digital inputs
- CANOpen with (optional) BLE communication
- Support multiple sensor configurations
- Single pulse and quadrature pedal or wheel speed inputs
- Analog and voltage model based battery management system interfaces
- Sensorless or hall commutation with automatic switching
- Configurable throttle, brake cut-off and regeneration options
- Fault protection including:
 - Bus over and under voltage
 - Motor over current
 - Motor and controller over temperature
 - MOSFET bridge self tests
 - Battery SOC foldback

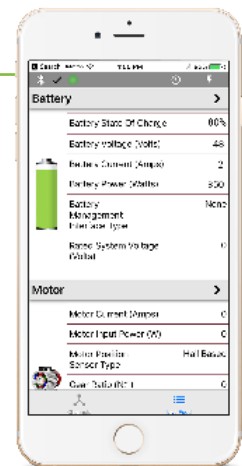

Includes BACDoor software to fine tune performance. Available for OEM customers.



Engineered in Canada

519.342.2507 | www.accelerated-systems.com

07.2019 © Accelerated Systems Inc. V.3.7

Specifications subject to change without notice.

SPECIFICATIONS

OUTPUT PHASE CURRENT CONTROLLER	
CONTROLLER	PEAK
BAC 2000	200 A-DC (141 A-RMS)
BAC 4000	430 A-DC (304 A-RMS)
BAC 8000	840 A-DC (594 A-RMS)

INPUT POWER (ALL CONTROLLERS)		
FEATURE	RATING	UNITS
Nominal Input Voltage	36-72	Volts DC
Input Power	Software configurable	

STANDARD COMMUNICATION PROTOCOL
CANOpen with optional BLE

CONTROLLER POWER AND PERFORMANCE	
PWM frequency	10 kHz default / up to 16.5 kHz when operating in remote mode
Maximum Controller output frequency	500 Hz
Electrical isolation to heatsink	500 VAC
Storage ambient temperature	-40°C to 85°C
Operating ambient temperature	-20°C to 50°C
Thermal cutback	Controller gradually reduces maximum output current when internal temperature is above 80°C, complete cutoff occurs above 95°C
Package environmental rating	IPx5 (w/fully populated connectors)
Speed regulation (range)	+/- 5% at top speed
Minimum motor phase to phase inductance	20 µH
Motor control scheme	Sinusoidal field oriented (FOC)
Motors supported	PMAC and BLDC

INPUT SPECIFICATIONS				
TYPE	QTY	VOLTAGE	VMIN	VMAX
Hall sensor inputs	3	Logic Low	0 VDC	0.5 VDC
		Logic High	3.5 VDC	5 VDC
Digital inputs	2	Logic Low	-0.3 VDC	1.2 VDC
		Logic High	4 VDC	5.3 VDC
5V analog inputs	3	Analog	0 VDC	5 VDC
10V analog inputs	1	Analog	0 VDC	10 VDC

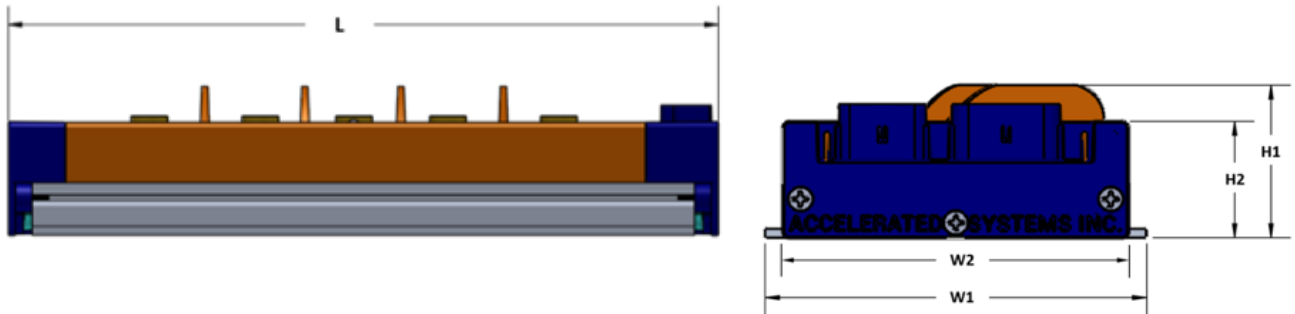

DIMENSIONS & WEIGHT													
MODEL	L		W1		W2		H1		H2		WEIGHT		
	mm	in	mm	in	mm	in	mm	in	mm	in	kg	lb	
BAC2000	125	4.92	126	4.96	114	4.5	49	1.93	39	1.54	1.02	2.25	
BAC4000	173	6.81	126	4.96	114	4.5	51	2.00	39	1.54	1.36	3.00	
BAC8000	246	9.68	126	4.96	114	4.5	52	2.05	39	1.54	2.04	4.50	

Pin Out Table

6 PIN MOLEX MX150 CONNECTOR			
PIN #	FUNCTION	FUNCTION (CLASSIC)	SPECIFICATIONS & RATINGS
1	Hall 5V output	Hall 5V output	20mA max
2	Hall GND	Hall GND	20mA max
3	Hall-A	Hall-A	0V OFF, 5V ON
4	Hall-B	Hall-B	0V OFF, 5V ON
5	Hall-C	Hall-C	0V OFF, 5V ON
6	Analog input 3	Brake 2 / Motor Temperature	0-5V (configurable pull-up/down)

Mating Connector: Molex MX150 6 Pin, Single Row, Female, Part # 0334710601

16 PIN MOLEX MX150 CONNECTOR			
PIN #	FUNCTION	FUNCTION (CLASSIC)	SPECIFICATIONS & RATINGS
1	Low side switch	HDQ	100mA max
2	Digital input 1	Cruise	Pulled up, active low
3	TTL-Tx	TTL-Tx	5V TTL
4	5V output	5V output	50mA max (combined with Pin 8)
5	Digital input 2	PFS	Pulled up, active low
6	Analog input 2	Brake 1	0-5V (configurable pull-up/down)
7	Analog input 1	Throttle	0-5V (pulled down)
8	5V output	5V output	50mA max (combined with Pin 4)
9	Logic power input	Key-in	Requires B+, may draw up to 100mA
10	CAN-L (optional 485-A, TTL2-Rx)	CAN-L (optional 485-A, TTL2-Rx)	Configurable 120 Ohm termination resistor
11	CAN-H	CAN-H	Configurable 120 Ohm termination resistor
12	Analog input 4	ABMS	0-10V (pulled down)
13	TTL-Rx	TTL-Rx	5V TTL
14	GND	GND	400mA max (shared between all grounds)
15	GND	GND	400mA max (shared between all grounds)
16	12V output	12V out	90mA max

Mating Connector: Molex MX150 16 Pin, Double Row, Female, Part # 0334721601